



PHONG TRÀO THIẾU NHI THÁNH THỂ VIỆT NAM tại HOA KỲ
THE VIETNAMESE EUCHARISTIC YOUTH SOCIETY in the U.S.A.

STUDENT WORKBOOK



Ngành Thiếu Nhi – SEARCH DIVISION
Cấp 1 – LEVEL I

Tên/Name: _____

Đội/Team: _____

Huynh Trưởng/Youth Leader: _____

Đoàn/Chapter: _____

Miền/Region: _____

Thánh Kinh



Scripture

Obedience

Sự Vâng Lời

Thánh Kinh # 1

Word of God

Luke 2:41 – 52

“Every year Jesus’ parents went to Jerusalem for the Festival of the Passover. When he was twelve years old, they went up to the festival, according to the custom. After the festival was over, while his parents were returning home, the boy Jesus stayed behind in Jerusalem, but they were unaware of it. Thinking he was in their company, they traveled on for a day. Then they began looking for him among their relatives and friends. When they did not find him, they went back to Jerusalem to look for him. After three days they found him in the temple courts, sitting among the teachers, listening to them and asking them questions. Everyone who heard him was amazed at his understanding and his answers. When his parents saw him, they were astonished. His mother said to him, “Son, why have you treated us like this? Your father and I have been anxiously searching for you.” “Why were you searching for me?” he asked. “Didn’t you know I had to be in my Father’s house?” But they did not understand what he was saying to them. Then he went down to Nazareth with them and was obedient to them. But his mother treasured all these things in her heart” And Jesus advanced in wisdom and age and favor before God and man.



Bible Case Study

- “Didn’t you know I had to be in my Father’s house?” But they did not understand what he was saying to them. Then he went down to Nazareth with them and was obedient to them. But his mother treasured all these things in her heart” And Jesus advanced in wisdom and age and favor before God and man (Luke 2:41 – 52). When Pharaoh did not obey God’s command to let his people go, God sent Moses to send plagues that swept throughout the land of Egypt.
- God told Abraham to bring Isaac, his only son to the top of Mount Moriah and kill Isaac as a sacrifice to show how much Abraham loved God. Abraham obeyed God and just as he was about to kill Isaac, God stopped him, because love is better than sacrifice.
- When Jesus was 12 year old, he went to the temple with Joseph and Mary, and was separated. Jesus stayed after they left and was at the temple. They looked for him for 3 days and found him with the teachers in the temple. When Joseph and Mary told him to return home with them, Jesus obeyed them because he realized how much they loved and cared for him.

Where are the Words?

Jesus always obeyed his mother and father because he knew how much they loved and cared for him.

Life Application

Parents/Teachers/Youth Leaders tell you:	Disobedience's Result:	Obedience's Result:
Do homework	1. 2. 3.	1. 2. 3.
Be honest, don't lie	1. 2. 3.	1. 2. 3.
Exercise, eat fruits & vegetables	1. 2. 3.	1. 2. 3.
Pray everyday	1. 2. 3.	1. 2. 3.

God stopped Abraham from killing Isaac because love is better than sacrifice

Summary

We should be obedient to our parents, family, and teachers. They are the ones that love us and want us to succeed in life. Because of this reason, they tell us what to do because they already know what's ahead. When we disobey them, we hurt them and we hurt ourselves, ultimately, we damage our future.

Prayer

Oh Lord, please teach me the ways of obedience. Help me follow your ways to live a Christian life. Let me have the patience and understanding to listen to my parents, family, teachers and Youth-Leaders, so I can become a good person and a good Catholic.

Homework

1. Why do you have to be obedient?

2. If I do not obey, how will it affect me and my future?

3. Who do you listen to the most? Why?



Goodness

Sự Tốt Lành

Thánh Kinh # 2

Word of God

Luke 10:29 – 37

But because he wished to justify himself, he said to Jesus, “And who is my neighbor?” Jesus replied, “A man fell victim to robbers as he went down from Jerusalem to Jericho. They stripped and beat him and went off leaving him half-dead. A priest happened to be going down that road, but when he saw him, he passed by on the opposite side. Likewise a Levite came to the place, and when he saw him, he passed by on the opposite side. But a Samaritan traveler who came upon him was moved with compassion at the sight. He approached the victim, poured oil and wine over his wounds and bandaged them. Then he lifted him up on his own animal, took him to an inn and cared for him. The next day he took out two silver coins and gave them to the innkeeper with the instruction, ‘Take care of him. If you spend more than what I have given you, I shall repay you on my way back.’ Which of these three, in your opinion, was neighbor to the robbers’ victim?” He answered, “The one who treated him with mercy.” Jesus said to him, “Go and do likewise.”



Bible Case Study

- Being good is not only about being right. Normally, everyone has their reason to do anything, and often think that they are right. Just like the other priest, Levite, they thought they were right, tending to their own business. The Good Samaritan was on his way to take care of his own business too; yet, when he saw that the victim needs assistance, he put everything aside to help him. Being good, ultimately is being concerned and doing good not just for oneself but also for others as well.
- When Mary, Jesus’ mother informed Him the wedding is running out of wine, Jesus refused to be concerned about it, justifying that “it’s not my time yet”. However, a moment later, He realized that it is good to put aside everything, including his own ego, self-interests (video games...) in order to help others when they are in need (wine = joy, happiness). Is time to watch TV, play video games, etc., or time to help out the chores to bring a little gladness and joy to the family!??
- Jesus is making a real, practical example of putting aside his own agenda, interests... so that he could help others/family/neighbors and bring joy and happiness to them. What are the few things that Thiều Nhi could do to bring joy and happiness to others?

Where are the Words?

Jesus teaches us that we cannot stand by and not help others when we have the capacity to do so. Apathy is also a sin.



Life Application

As we read the story of the new preacher who moved to Texas, we see that life is a place where we get to apply what we have been taught. From the preacher, had he kept the quarter, though it isn't much, he would have turned the bus driver away who is searching for God. When we are good and we do good deeds or make good moral decisions, we naturally will attract goodness and God's grace into our lives.

1. What benefits do I get when I am good?

2. Who should you be good to?

Good means being able to have a clear understanding between rights and wrongs; be able to make the right decisions under difficult situations.

Summary

During our upbringing, we were taught what is right and wrong from our parents and society. As we go through life, we are expected to have used what we learned and apply them. As such, we are able to make good moral judgment and rid ourselves from all the sins surrounding us. We need to keep our body, mind and soul pure through doing good deeds and make good moral judgment so that we can be a temple for Jesus. It is in us where Jesus will reside through Communion.

Prayer

Oh Lord, please help me to find the courage to be good in your name. Help me understand what it means to be a good catholic to have a fulfilling life. Let me have the patience and understanding to see the goodness in others as well as myself in order to help spread your love.



Making Choices

Sự Chọn Lựa

Thánh Kinh # 3

Word of God

Matthew 21:28 – 32

“What is your opinion? A man had two sons. He came to the first and said, ‘Son, go out and work in the vineyard today.’ He said in reply, ‘I will not,’ but afterwards he changed his mind and went. The man came to the other son and gave the same order. He said in reply, ‘Yes, sir,’ but did not go. “Which of the two did his father’s will?” They answered, “The first.” Jesus said to them, “Amen, I say to you, tax collectors and prostitutes are entering the kingdom of God before you.

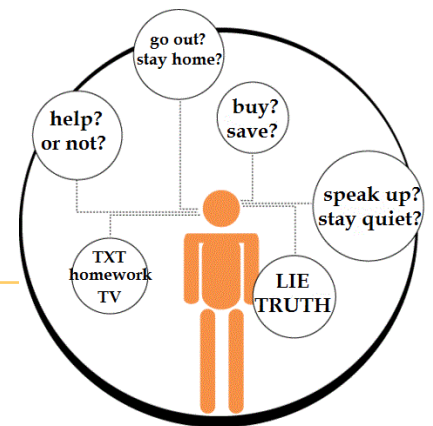

Bible Case Study

RIGHT choice is usually harder than making/doing the wrong choice. For example, it is harder to speak up about a harsh truth that people will hate you for than to tell a sweet lie that people will love you for it.

- Bible: 10 commandments, 8 beatitudes ...
- Sunday school: moral lessons, character building, leadership ...
- Academic school: knowledge through learning, health through physical education ...
- Parents & Good Family Members: discipline through doing chores, good manners, good behavior, love ...

WRONG choices are based on sins and temptations:

- Anger: get mad at parents and friends if things do not go your way (e.g.: slam door, yell at your parents ...)
- Greed: want to buy things, want more money (e.g.: have got to have the newest phone, clothes, shoes ...)
- Pride: too proud, conceited (e.g.: too proud to admit your own fault)
- Sloth: lack of sympathy; also means inactivity that leads to wastefulness (e.g.: too much TV/internet/Facebook, they waste away your mind)
- Envy: jealous of other people, not happy with what you have (e.g.: talk badly about people better than you)
- Lust: sex, pornography...
- Gluttony: over eating, eating wrong foods, not exercising (ex: veggies do not taste good and fries, milk shakes, chips taste better)

Life Application

Choices and where they lead you in life:

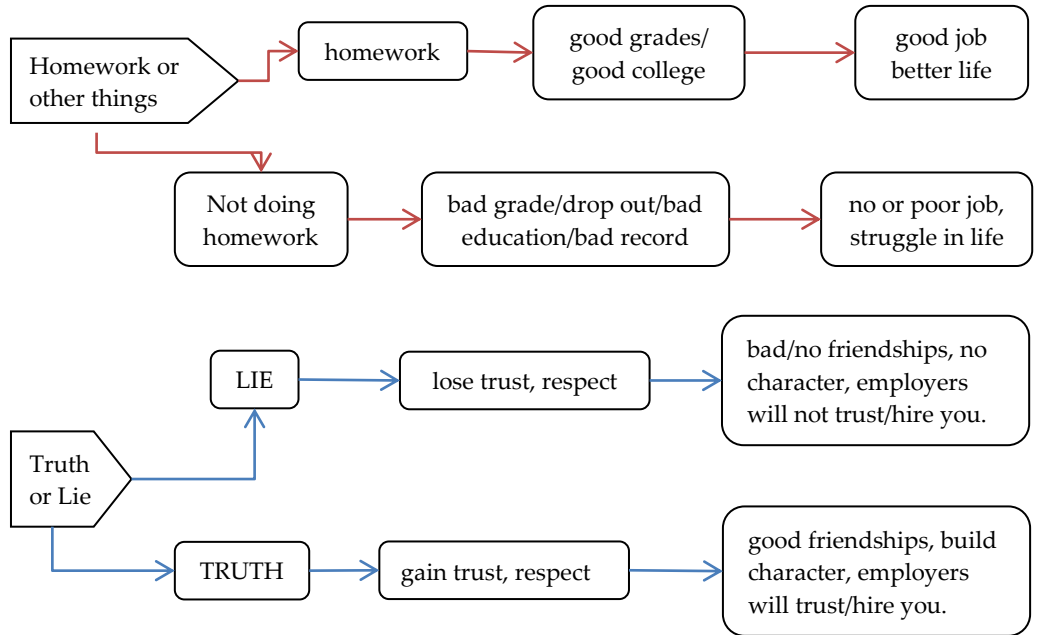

Summary

1. We can make the same kinds of choices Jesus made (sacrificing His life to save us, helping the poor and curing the sick).
2. Refer to the teachings of Bible, Thiếu Nhi/Giáo Lý/Việt Ngữ, school, parents when making choices.
3. Good Choices are often hard to do/make while Bad Choices are always easier.
4. Good Choices have Positive long-term results while Bad Choices have both immediate and long-term Negative results.
5. Remember to pray when you are making difficult choices.
6. You are responsible for the consequences of the choices that you have made.

Where are the Words?

The first four apostles had a choice: leave everything behind to follow Jesus or live the way they are. They chose to follow Jesus, and now they are all saints!

Prayer

Dear Lord Jesus, You are the way, the truth, and the life, please help us so we may make decisions based on Your teachings.

Homework

1. Why should we make the good/right choices?

2. What are the consequences of bad/wrong choices?

3. Share with the group a tough decision you made last week or previously, and what helped you made that decision.



Forgiveness

Sự Tha Thứ

Thánh Kinh # 4

Word of God

John 8: 1 – 11

“Jesus went to the Mount of Olives. At dawn he appeared again in the temple courts; where all the people gathered around him, and he sat down to teach them. The teachers of the law and the Pharisees brought in a woman caught in adultery. They made her stand before the group and said to Jesus, “Teacher, this woman was caught in the act of adultery. In the Law Moses commanded us to stone such women. Now what do you say?” They were using this question as a trap, in order to have a basis for accusing him. But Jesus bent down and started to write on the ground with his finger. When they kept on questioning him, he straightened up and said to them, “Let any one of you who is without sin be the first to throw a stone at her.” Again he stooped down and wrote on the ground. At this, those who heard began to go away one at a time, the older ones first, until only Jesus was left, with the woman still standing there. Jesus straightened up and asked her, “Woman, where are they? Has no one condemned you?” “No one, sir,” she said. “Then neither do I condemn you,” Jesus declared. “Go now and leave your life of sin.”

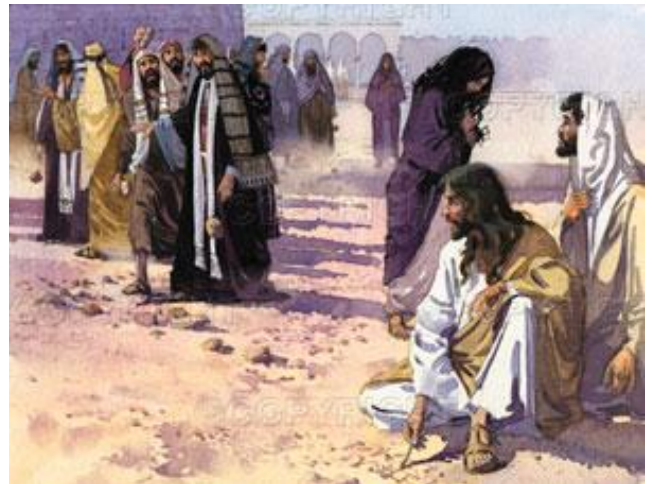

Bible Case Study

Forgiveness is very powerful tool for it has the power of releasing someone from guilt and pain; however, it is a very hard skill to achieve. Think back of a time where you had to forgive someone when they hurt you emotionally. For instance, you came home and found your room a mess because your younger siblings messed it up. Automatically, you would be irritated by the thought that someone has gone through your personals without even asking. You will notice that it takes a lot of will power to forgive someone. Imagine how Jesus felt when he had to forgive each and every one of us for our wrong doings.



Where are the Words?

*“If we really want to love, we must learn how to forgive”
Mother Teresa*



Life Application

Take a couple minutes and reflect about your life and those who have done you wrong. Now think about the times that you have done wrong to others. As we see we have first and foremost hurt others; therefore, we should be more understanding to those who have done us wrong and try to forgive them.

Summary

It is human nature for us to judge people who have done us wrong. However, we need to first understand we are neither the judge nor jury. We ourselves are also imperfect and sinful. This lesson encourages us to model after Jesus who is the all loving and merciful Father. Just as Jesus forgave the woman who committed adultery, we should imitate Him to forgive others. Just as He gave the woman a second chance, we too should give one another a second chance.



Prayer

Dear Lord, please help me to learn the passion of your forgiveness when we have done wrong. So that I can follow in your footsteps and learn how to forgive those who have done me wrong. Let me understand that mean of love, so that I am able to love and forget my anger and be able to not sin myself and make you angry.

Forgiveness is not something we do for other people. We do it for ourselves to get well and move on.

Homework

Write a letter to a person that you are angry with by expressing to them how you feel when they made you mad and discuss how you plan to forgive them. Share with the group your experience next week.

Prayer

Sự Cầu Nguyện

Thánh Kinh # 5

Word of God

Matthew 5:9 – 15

“This is how you are to pray: Our Father in heaven, hallowed be your name, your kingdom come, your will be done, on earth as in heaven. Give us today our daily bread; and forgive us our debts, as we forgive our debtors; and do not subject us to the final test, but deliver us from the evil one. If you forgive others their transgressions, your heavenly Father will forgive you. But if you do not forgive others, neither will your Father forgive your transgressions.



Bible Case Study

Prayer is a form of religious practice that seeks to activate a volitional rapport to God through deliberate practice. Prayer may be either individual or communal and take place in public or in private. It may involve the use of words or song. When language is used, prayer may take the form of a hymn, incantation, formal creed, or a spontaneous utterance in the praying person. There are different forms of prayer such as petitionary prayer, prayers of supplication, thanksgiving, and worship/praise. Prayer may be directed towards God, a deceased person, or lofty idea, for the purpose of worshipping, requesting guidance, requesting assistance, confessing sins or to express one's thoughts and emotions. Thus, people pray for many reasons such as personal benefit or for the sake of others.

Scientific studies regarding the use of prayer have mostly concentrated on its effect on the healing of sick or injured people. The efficacy of petition in prayer for physical healing to God has been evaluated in numerous studies, with contradictory results. There has been some criticism of the way the studies were conducted.

Where are the Words?

Singing for is like praying twice

Life Application

Create your own prayer!

On a piece of paper write down:

- a. why you love Jesus;
- b. what you are thankful about;
- c. what do you want Jesus to know
- d. what do you want Jesus to do to you.

Once you are done, read a-b-c-d together and you have your own personal prayer.



Prayer is important—just count how many times we pray in mass!

Summary

Prayer is way for us to communicate with God, our deceased loved ones, and for those around us. It is through prayer that we can ask for certain guidance within our lives to make us better Catholics. As now we can see that prayer isn't about repeat the same prayer over and over, however, is our expression towards God through music, letters, thoughts, and others where prayer can be used as a way to communicate with our closest and dearest friend that loves us unconditionally.

Prayer

Lord Jesus, may everything I do begin with You, continue with Your help, and be done under Your guidance. May my sharing in the Mass free me from my sins, and make me worthy of Your healing. May I grow in Your Love and Your service, and become a pleasing offering to You; and with You to Your Father. May the mystery I celebrate help me to reach eternal life with you.

Homework

Offer day and night prayers every night this coming week and prepare to share with the class how the experience changes you.



Thánh Thể

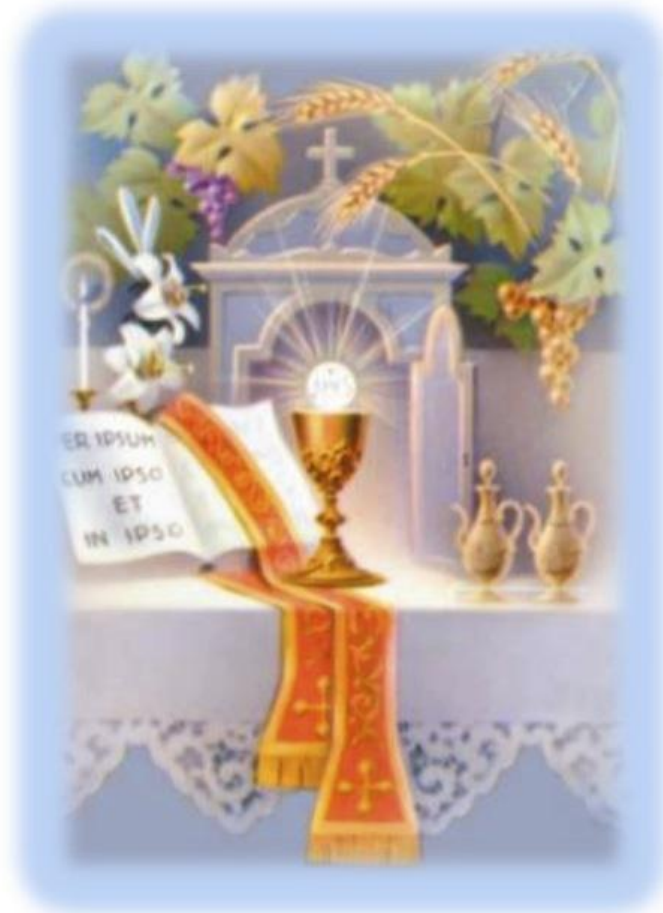

Eucharist

Introductory Rites

Nhập Lễ

Thánh Thể # 1

Reading the Bible

Luke 24: 36

And as they thus speak, Jesus himself stood in the midst of them, and said unto them, Peace be unto you.

Studying Our Faith

INTRODUCTION RITES

- THE SIGN OF THE CROSS

WE CALL UPON THE HOLY TRINITY



**Where are
the Words?**

*Gloria is not
sung during
Advent and Lent
seasons*

- We begin our Mass as we begin any prayer, with the sign of the cross. We are calling upon God to be with us as we pray to Him.

• THE GREETING

WE ARE WELCOMED IN GOD'S NAME

- "The grace of our Lord Jesus Christ and the love of God and the fellowship of the Holy Spirit be with you all."

The greeting part is like singing the Anthem, invoking patriotism before starting the sport event or other events.



- The priest greets us and welcomes us to church. The priest INVOKE God's Name to begin the liturgy. The greeting part on his behalf is in the next section. It is like singing the Anthem, invoking patriotism before starting the sport event or other events.
- Therefore, when the priest celebrates the Mass, he is NOT doing it in his own name, but in the name of God: The Father, The Son and the Holy Spirit. Moreover, the Greeting is meant to acknowledge the presence of God among the community and how the Church is gathered and united in the celebration of the sacred liturgy.

• THE PENITENTIAL RITE

WE EXPRESS SORROW FOR OUR SINS

- "I confess to almighty God, and to you, my brothers and sisters, that I have sinned through my own fault, in my thoughts and in my words, in what I have done and in what I have failed to do. And I ask blessed Mary, ever virgin, all the angels and saints, and you, my brothers and sisters, to pray for me to the Lord our God."
- The priest now invites us to think of our sins and tell God that we are sorry for them. We want to apologize for having been selfish and for having sinned so that we can listen to God's word and to receive His body and blood with a pure heart.



• THE GLORIA

WE PRAISE GOD

- *Glory to God in the highest, and peace to his people on earth. Lord God, heavenly King, almighty God and Father, we worship you, we give you thanks, we praise you for your glory. Lord Jesus Christ, only Son of the Father, Lord God, Lamb of God; you take away the sin of the world, have mercy on us; you are seated at the right hand of the Father: receive our prayer. For you alone are the Holy One, you alone are the Lord, you alone are the Most High, Jesus Christ, with the Holy Spirit, in the glory of God the Father. Amen.*
- The Gloria: An old prayer to glorify the Holy Trinity, the Church use it to portray the pleasure and joy and the solemn of Mass of the day. This prayer is chanted on Sundays besides those of advent and lent seasons, in Mass of solemnity, feast, and special occasion.

• THE OPENING PRAYER

WE PRAY FOR ALL OUR NEEDS

- The priest prays in the name of all who are present. He asks the Lord to guide our thoughts, our prayers, and our love.
- In this prayer, the priest asks God to be with us in a very special way as we open our hearts to him.
- Now we are so happy God has promised us his forgiveness that we have to celebrate. We do this by saying or singing the song that the angels sang so long ago when they celebrated the birth of Jesus in Bethlehem.

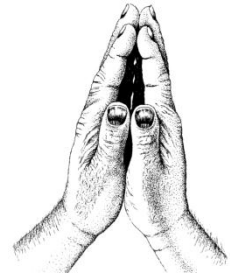

Summary

1. **The Sign of the Cross:** We Call Upon the Holy Trinity
2. **The Greeting:** We Are Welcomed In God's Name
3. **The Penitential Rite:** We Express Sorrow For Our Sins
4. **The Gloria:** We Praise God
5. **The Opening Prayer:** We Pray for All Our Needs

Prayer

Dear Lord Jesus, help me to stay focus so that I may benefit from your abundance grace during the Eucharistic celebration.

Practicing Our Faith

The next time you are in church, remember to do the Sign of the Cross wholeheartedly and reexamine you sins as the priest invite you to say the penitential rites.

Liturgy of the World

Phụng Vụ

Lời Chúa

Thánh Thể # 2

Reading the Bible

Luke 24: 44 - 48

Then he told them, 'This is what I meant when I said, while I was still with you, that everything written about me in the Law of Moses, in the Prophets and in the Psalms, was destined to be fulfilled.' He then opened their minds to understand the scriptures, and he said to them, 'So it is written that the Christ would suffer and on the third day rise from the dead, and that, in his name, repentance for the forgiveness of sins would be preached to all nations, beginning from Jerusalem. You are witnesses to this.'



Studying Our Faith

LITURGY OF THE WORD

I. FIRST READING

GOD SPEAKS TO US THROUGH THE PROPHETS



- We sit and listen to the Word of God as it was spoken in the Old Testament, especially through his prophets. The reader takes their place in speaking to us.

II. SECOND READING

GOD SPEAKS TO US THROUGH THE APOSTLES

- We now listen to readings taken from the letters of Paul and the other apostles.

III. THE GOSPEL

GOD SPEAKS TO US THROUGH CHRIST

- The priest or deacon reads the gospel in the name of Jesus, and Jesus himself becomes present among us through his word.

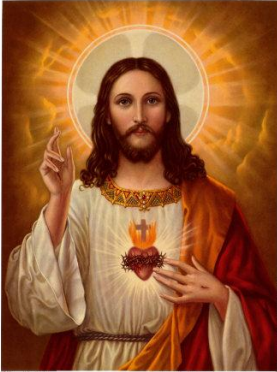

IV. PROFESSION OF FAITH

WE PROFESS OUR FAITH

- The Creed: an act to respond to the words of God, a profession of faith which every believer professes together before the celebration of the Eucharist. The creed is said or sung together by everybody.



V. GENERAL INTERCESSIONS

WE PRAY FOR OUR BROTHERS AND SISTERS IN CHRIST

- a. We begin by praying for the Church. We pray for the Pope, the bishops, priests, all deacons, and all of the people of God. We pray that we might all answer God's call in a loving manner.
- b. We pray for the public authorities, the leaders of our nation, and all the people of the world.
- c. We also pray for those who have a special need. We pray for the poor, for those who are sick, for those who are sad, and for anyone else who might need our prayers.
- d. We pray for those who have died. We remember them because we want to share our love with them and pray that they might be with God in heaven.
- e. Finally, we pray for our own local community and our particular needs.

Where are the Words?

The Liturgy of the Word lets us hear about the salvation works of God throughout history to prepare us to receive Jesus, who is the ultimate salvation your point of interest here.

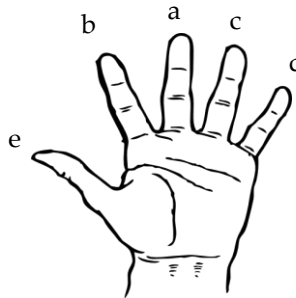

Summary

- God nourishes us with His Word before He gives us His own body to nourish our soul.
- These readings come from both the Old Testament and the New Testament. They speak of God's love for us throughout history and especially of God's love shown to us in Jesus.

Prayer

Most Holy Jesus, I adore you. Please help me to be persistent in my habit of reading your Words daily. Amen!

Practicing Our Faith

The next time you are in church, pay close attention to the first reading and see if you know which Testament it is from, which book in the bible, and the meaning of it?

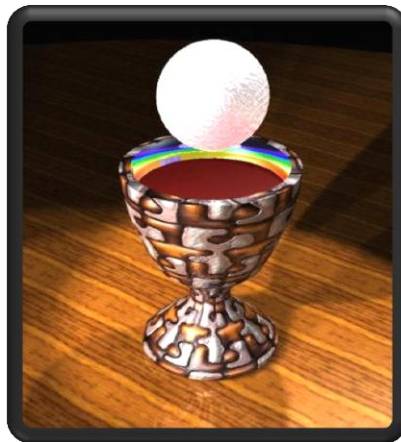

Liturgy of the Eucharist

Phụng Vụ Thánh Thể

Thánh Thể # 3

Reading the Bible

Matthew 26: 26-28

While they were eating, Jesus took bread, said the blessing, broke it, and giving it to his disciples said, "Take and eat; this is my body." Then he took a cup, gave thanks, and gave it to them, saying, "Drink from it, all of you, for this is my blood of the covenant, which will be shed on behalf of many for the forgiveness of sins."

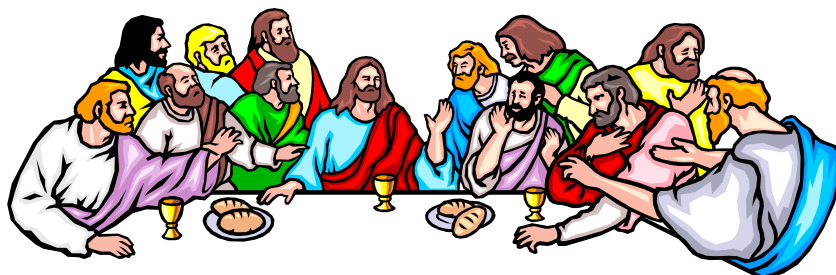

Studying Our Faith

LITURGY OF THE EUCHARIST

I. COLLECTION FOR THE CHURCH

- We collect money from all the mass to help fund for our parish, our diocese, and the Catholic Church as a whole.



II. PREPARATION OF OFFERINGS

WE OFFER BREAD, WINE, AND WATER



Mixture of Water and Wine



- Bread and wine signifies body and blood of Christ.

III. PRAYER OVER THE GIFTS

WE PRAY FOR GOD'S GRACE

IV. PRIEST WASHES HAND

- Priest washes away his sins before handling Eucharist.

V. INVITATION TO PRAYER

WE ASK GOD TO ACCEPT OUR SACRIFICE



Prayer over the Gift



VI. EUCHARISTIC PRAYER

- Thank God for his Sacrifice
- Praise God for his Sacrifice
- Praise Holy with the angels

VII. CONSECRATION OF BREAD AND WINE

- Repeat Jesus' words during Last supper and turn the bread into his body and wine into his blood.

VIII. PROCLAMATION OF OUR FAITH

- We proclaim that Jesus died, came back to life, and will come again.

IX. PRAYER FOR THE REMEMBRANCE FOR THE DEAD SOULS

- We pray for the souls in purgatory and the people that passed on.

X. PRAISING JESUS

- We praise Jesus for his Glory

Where are the Words?

"Transubstantiation" is a big word, though it simply means the bread and wine used during the Eucharist becomes the true body and blood of Christ.

Summary

1. Collection for the Church
2. Preparation Of The Gifts: Bread, Wine, and Water
3. Prayer Over The Gifts
4. Priest Washes His Hand
5. Invitation Prayer
6. Eucharist Prayer
7. Consecration of Bread and Wine
8. Proclamation of our Faith
9. Prayer and Remembrance for the dead souls
10. Praise for Jesus

Prayer

Dear Lord Jesus, help me to stay focus so that I may benefit from your grace during the Eucharistic celebration.

Practicing Our Faith

Before a meal, we should clean our hands so we wouldn't get sick. Similarly, before we receive the Eucharist, we should cleanse our soul so that God can reside in it. Another example is when our relatives from far away visit our house; we need to prepare a clean place for them to stay at. It's not polite if our house is filthy or disorganized. By cleaning our soul for God, we express our love and respect to God, our creator.

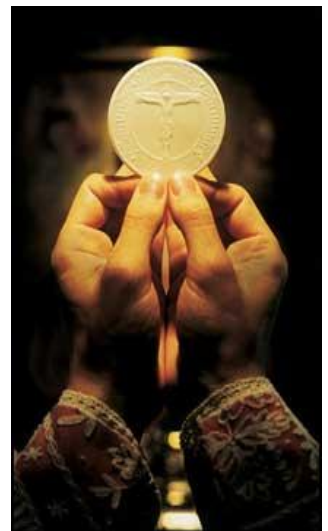

Liturgy of the Eucharist II

Phụng Vụ

Thánh Thể II

Thánh Thể # 4

Reading the Bible



Matthew 6:9-13

“This is how you are to pray: Our Father in heaven, hallowed be your name, your kingdom come, your will be done, on earth as in heaven. Give us today our daily bread; and forgive us our debts, as we forgive our debtors; and do not subject us to the final test, but deliver us from the evil one.

Studying Our Faith

LITURGY OF THE EUCHARIST (CONT.)

I. OUR LORD'S PRAYER

The Prayer Jesus taught us directly. We pray that He may provide us with the spiritual nourishment and through His love, we shall be saved.

II. THE SIGN OF PEACE

We give peace to each other.



III. BREAKING THE BREAD

We ask for mercy and peace



Where are the Words?

In the 8th Century AD, the bread and wine used during a mass in Lanciano, Italy physically turned into human blood and flesh. It is considered as the greatest Eucharistic miracle of the Catholic Church.

IV. LAMB OF GOD PRAYER

Jesus is the sacrificial lamb that died for us so we



V. COMMUNION

We receive and united with Jesus' body and blood.



VI. PRAYER AFTER COMMUNION

We ask for the grace of communion.

Summary

1. Our Lord's Prayer
2. Sign of Peace
3. Breaking the Bread
4. Lamb of God Prayer
5. Communion
6. Prayer after Communion



Prayer

Dear Lord Jesus in the Eucharist, you have invited us to join your most Holy Celebration of the Eucharist. May we receive your precious Body and Blood so that we may inherit eternal life. Amen!

Practicing Our Faith

After genuflection in adoration, the priest raises the Host so that we may also adore Jesus Christ, true God and true Man present on the altar. Look at the sacred Body of Jesus and pray with all your heart: "I adore You, O Sacred Body of Jesus Christ, You are my Lord and my God; I believe in You, I hope in You, I love You above all things."

When the priest holds up the Chalice for the people to adore, look at the Chalice and pray with all your heart: "I adore You, O Sacred Blood of Jesus Christ; You are the price of my salvation. Cleanse and preserve my soul to life everlasting."

Concluding Rite

Kết Lễ

Thánh Thể # 5

Reading the Bible

Romans 10: 15

And how shall they preach, except they be sent? As it is written, how beautiful are the feet of them that preach the gospel of peace, and bring glad tidings of good things!

Studying Our Faith

CONCLUDING RITE

I. PRAYER AFTER COMMUNION

WE ASK FOR THE GRACE OF COMMUNION

- Thank God for being one with us.

II. THE BLESSING

WE RECEIVE GOD'S BLESSING FROM THE PRIEST

- The Mass closes with a sign of the cross, just as it began with one. This time the sign of the cross is a blessing.



Where are the Words?

The closing song is actually not a required part of mass.

Summary

1. Prayer After Communion
2. The Blessing

Prayer

Dear Lord, thank you for giving me a life of freedom of choice. Please let me always choose You and live my life as You would have me live it.

Practicing Our Faith

During the week, you should help Jesus spread the Word by helping others in school, church, family, and friends. This way, you're living with the Mass in your life, as well as living how Jesus did.

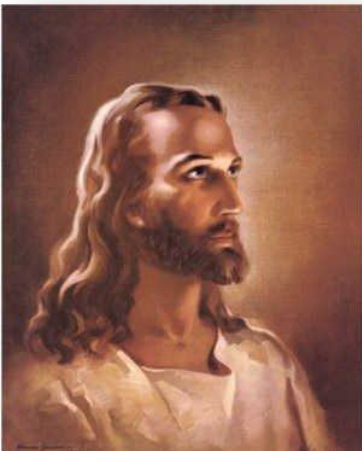

Phong Trào



VEYS

Purpose and Foundation

Mục Đích và Nền Tảng

Phong Trào # 1

Fact Finding

Purpose: The goals of the Eucharistic Youth Society are

1. To educate youths in both social and spiritual life and help them become better people and responsible Christians.
2. To organize and guide all youths and help them become more aware of the Church's mission to the world by engaging in the spreading of Good News, and be involved in working for the good of society through apostolic services, in serving others.



Foundation: The foundation of the Eucharistic Youth Society is

To use the word of God from the bible and the teachings of the church, in order to train and guide the youth in all their works.



Where are the Words?

*A lot of people see
us and they think
we're just scouts.*

*In fact, the
purpose of TNTT
is very different!*

Summary

- The purpose of TNTT is made up of two parts.
 - The 1st purpose of TNTT is to educate the youth to become a better person and a better Christian.
 - The 2nd purpose of TNTT is to engage the youth to spread the Good News.
- The ultimate goal is to help the youth to become holy (saints).
- The foundation of TNTT is the bible and traditions of the church

Homework

1. Go home and turn to a random verse in the bible, and read it and copy it down on a sheet of paper. What does this passage or verse of the bible mean to you?

2. What are some things you do to become a better Christian?

3. What are some ways you can become a better person?

4. How have you spread the Good News?



Ideal and Principles

Lý Tưởng và Tôn Chỉ

Phong Trào # 2

Fact Finding

Ideal

The Eucharistic Youth Society accepts Jesus in the Eucharist as the ideal and source for a spiritual life.

Principles: The principles of the Eucharistic Youth Society are

1. To live the Word of God and to unite with Jesus in the Eucharist through the life of prayer, of Holy Communion, of sacrifice, and of apostolic works.
2. To love and honor Mary as the Mother of Christ as a model for discipleship.
3. To honor and imitate the 117 Vietnamese Martyrs that has died for their religion.
4. To love, obey, and promote prayers for the Holy Father who is the Vicar of Christ on earth and to pray for the needs of the whole Church.
5. To improve oneself and preserve the Vietnamese culture and traditions.



Where are the Words?

Here's an easy way to remember the 5 principles:
Jesus, Mary,
Saints, Pope,
Self

Summary



- The Jesus in the Eucharistic is our symbol.
- Jesus is the source of our spiritual life.
- There are five objectives for the Eucharistic Youth Society.
- Honor Mary Mother of Christ.
- Honor and imitate the Vietnamese Martyrs.
- Pray and love the Pope.
- Pray, receive communion, sacrifice, and do apostolic works.
- Improve and preserve the Vietnamese tradition and culture.

Homework

1. Say a short prayer each morning and pray for the Pope.

2. Pick one chore that you dislike to do and do it.

3. Learn one new piece of information about the Vietnamese Tradition from your parents and share with the group next week.

Chuyên Môn

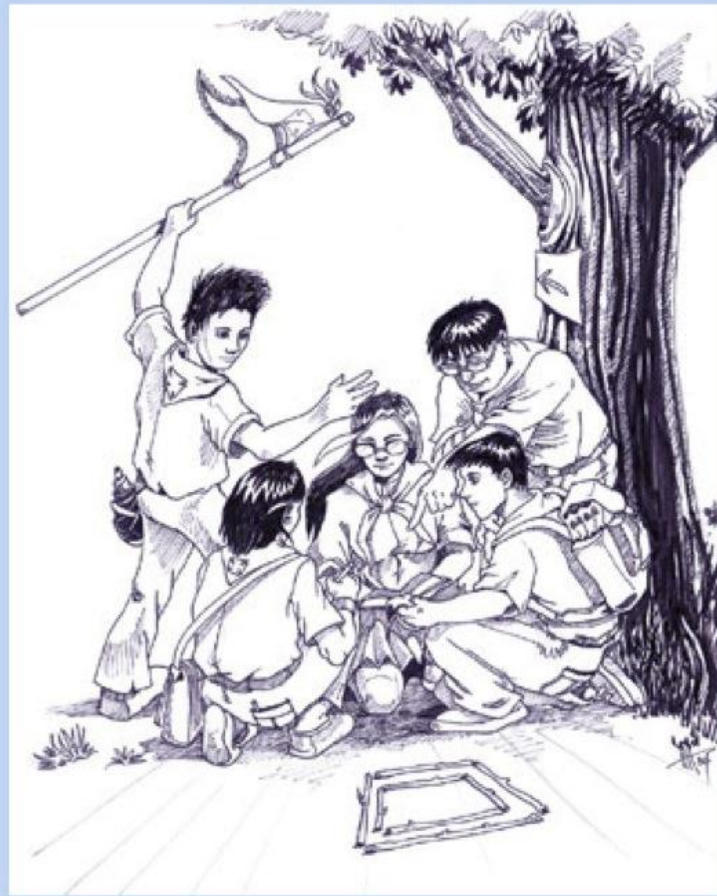

Skills

Introduction to Morse

Giới Thiệu về Morse

Chuyên Môn # 1

Fact Finding

Introduction to Morse

Morse is form of communication using sounds to transmit textual information.

Situation

When do you use Morse code in TNTT?

- To call kids into line formations
- To relay a message

Why does TNTT use Morse code in these situations?

1. Line formations: We use Morse code to call the kids into line formations. We use the abbreviations of each ngành to differentiate between the ngành that we are calling into formation.
2. Relaying messages: At Thiếu Nhi we can relay coded messages written in Morse code. This can be used to start "The Journey of Faith" activities. They can also be used written down so that others can decode a secret message.



Where are the Words?

Morse code is tiếng Việt friendly. They use S, Q, Z, X and J to substitute for dấu sắc, huyền, hỏi, ngã and nặng.

Morse Pyramid

We can use the Morse Pyramid to help us learn the Morse Letters.

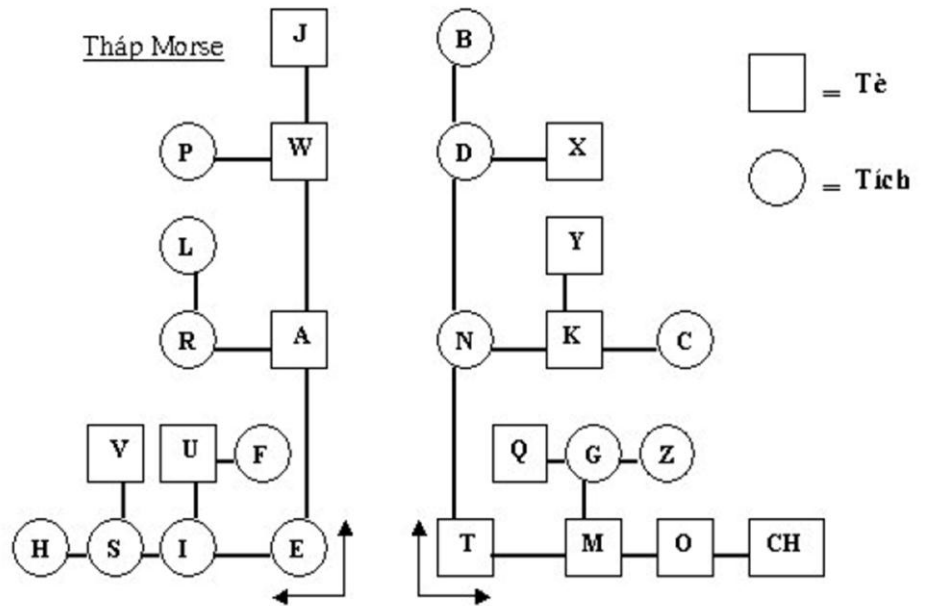

Summary

- Morse is used to send messages.
- Morse is used to assemble TNTT.

Prayer

Dear Jesus, help me learn new things with my friends every day.

Morse Code

A – Z, 0 – 9

Chuyên Môn # 2

Fact Finding

Morse Code Alphabet and Numbers

A ··	J ····	S ···	1 ·····
B ····	K ···	T -	2 ·····
C ····	L ····	U ···	3 ·····
D ···	M ··	V ····	4 ·····
E ·	N ··	W ···	5 ·····
F ····	O ···	X ····	6 ·····
G ···	P ····	Y ····	7 ·····
H ····	Q ····	Z ····	8 ·····
I ··	R ···		9 ·····
			0 ·····



Learning Strategy

Review the sound represented in Morse code. The short sound (tích) stands for the dot. The longer (tè) stands for the dash. Practice listening to the different letters that are blown and record them down on paper.

Where are the Words?

To call for help using Morse code, blow tích tích, tè tè tích tích, tè tè, tích tích tích. It stands for S.O.S.

Prayer

Dear Jesus, help me learn new things with my friends everyday.

Nghiêm Tập



Formations

Stances & Formations

Các Thế Căn Bản & Các Đội Hình

Nghiêm Tập # 1

Fact Finding

Basic Stances

There are the two stances:

1. At Attention – Stand with feet together and with the heels of your feet touching. The front of the feet should be apart at a 45 degree angle. The hands should hand straight down by the side of the body.
2. At Ease – Feet should be shoulder width apart. The hands will be behind the back with the left palm holding the right wrist and placed along the belt line



Formations

1. Vertical Line: Used to call all groups together. Groups do not need to run behind the trưởng trực. The group leaders need to stand between 3-5 steps away when lining up in the formation. Only the group leader salutes the trưởng trực.
2. Horizontal Line: Used as a way to present the group to a youth leader. The group needs to run around the person calling them one time, and then lines up with all members horizontal to the person calling them. In this formation, all team members must salute the trưởng trực.
3. Semi/Half Circle: Used to teach lessons in an outdoor setting. This is because the teacher can see all students at a quick glance. To get in formation, the team needs to run around the trưởng trực and the leading group stops at their right shoulder level. The teams do not need to organize their team. Once the formation is set, all team members need to salute the trưởng trực.
4. Circle: Used to play games and icebreakers. When the teams are called, all teams run around the person calling them until a circle is formed. As teams are running, the leading team starts a song that all groups will sing along with. The groups do not stop until the trưởng trực blows a whistle to stop them. Once stopped, the team leader of the leading group announces so that all members salute the trưởng trực.

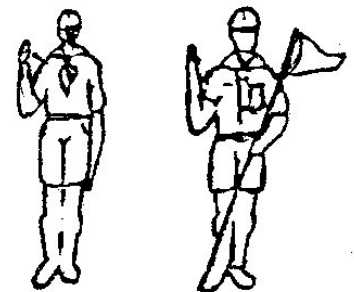
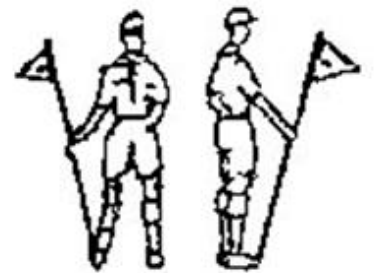

5. Letter U: This is used as a formal opening or closing ceremony. When called, the groups must run around the trưởng trực and stop at their shoulder level. The first group will line up and organize their group; the group leader of the next group will line up along with the first group and then turn to organize their group. This continues until the last group is in place.



Summary

- There are the two stances: at attention and at ease
- The five formations are vertical line, horizontal line, semi/half circle, circle and

Prayer

Dear Lord, please be with me as I learn the proper ways of lining up.

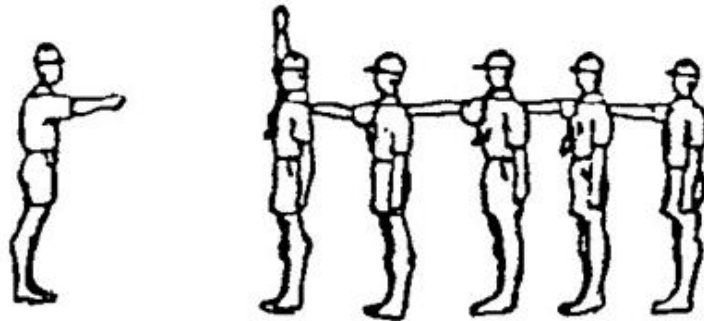

Individual & Team Presentation

Trình Diện Cá Nhân và Đội

Nghiêm Tập # 2

Fact Finding

Individual

- When you're called to present, fix your uniform.
- Advance forward and stand in front of the Youth Leader 3 steps, stand at attention stance, salute the Youth Leader.
- Once you finish the interaction with the Youth Leader, salute and return to your position.

Multiple Individuals

- When you're called to present, fix your uniform.
- Line up in the horizontal line 3 steps away from the Youth Leader (middle person in front of Youth Leader).
- The person standing to the furthest left of the Youth Leader gives the order to salute (lower hand after Youth Leader lowers hand).
- Once you finish the interaction with the Youth Leader, salute and return to your position (far right person gives the command).

Team

- Once your team receives the invitation to present, the team leader instructs the team members to fix their uniforms.
- The team leader yells the team's name and the team responses.
- The team leader leads the team counter-clockwise and line up horizontally to the Youth Leader 4 steps.
- The team leader organizes his/her team and salute the Youth Leader.
- The team leader advances forward to meet with the Youth Leader and return upon completion.
- The team leader instructs the team to salute and return back to their positions.



Summary



- It is important to understand why we follow these formalities.
- We institute them so we can demonstrate a level of respect for each other.
- By implementing these formalities we are also disciplining our mind and body.
- It also demonstrates an organized system of order so that TNTT from all around share a common system.

Prayer

Dear Lord Jesus, as I learn about the different methods of presenting self or team, please send your Holy Spirit on me so that I may be an effective Search member. Thank you, Jesus!



Ca Hát



Songs

Search Division Official Song

Thiếu Nhi Ca

Ca Hát # 1



1. Em THIẾU NHI ơi, như
2. Em THIẾU NHI ơi, mắt

ngàn tia sáng huy hoàng, vào buổi rạng đông
nhìn em ví sao trời, nụ cười trên môi

đến mang nguồn hơi ấm. Em THIẾU NHI
xoá tan màu u tối. Em THIẾU NHI

ơi, em đẹp như hoa hướng dương, tươi
ơi, em là chiến sĩ phúc âm, gian

dịu như hơi gió xuân đem
khổ nguy khó chốn nao vui

yên vui đến muôn người. (Em...)
mang Chúa đến cho người.

Meaning of Song

The Search Division Youths are like a thousand rays of sunlight bringing warmth in the dawn.

You are beautiful as a sunflower; fresh like the spring air bringing happiness to everyone.

Your eyes are stellar; the smile on your lips takes away the darkness.

You are a fighter for the Gospels, not scared of obstacles and hardships, happily bringing God to everyone

TNTT Motto Song

Khẩu Hiệu Thiếu Nhi

Ca Hát # 2



Cầu Nguyện, Rước Lễ, Hy Sinh, Làm Tông
Đồ. Khẩu hiệu Thiếu Nhi em bền tâm tuân giữ.
Cầu Nguyện, Rước Lễ, Hy Sinh, Làm Tông Đồ.
Khẩu hiệu Thiếu Nhi em chẳng quên bao giờ.

Translation

Pray, receive communion, sacrifice, do apostolic deeds. The slogan of TNTT
I will always keep.
Pray, receive communion, sacrifice, do apostolic deeds. The slogan of TNTT
I will never forget.

Meaning of Song

This song talks about the four mottos of TNTT. They are to pray, communion, sacrifice, and doing apostolic works. It talks about the promise of keeping and living these mottos and never forgetting them. This is the motto of Thiếu Nhi Thánh Thể and a way of life. .



Walking with Jesus

Ca Hát # 3



**Jesus on my left, Jesus on my right.
He loves all of us and He walks by our Side.
One step to the left, one step to the right.
We turn, and we clap, and we shout
Jesus Christ! Jesus Christ!**

Meaning of Song

Because Jesus loves us, He is always beside us wherever we go.
Jesus is our friend, so we should be happy and play together in His presence.

Anh Em Ta Về

Ca Hát # 4



Translation

Brothers and sisters come to gather together; one, two, three, four, five. Brothers and sisters come together to reunite; five, four, three, two, one. One, step evenly together. Two, turn and face one another. Three, hold hands tightly so no one separates. Four, remember we are all brothers and sisters in one home. Five, remember this feeling of love forever in the words we sing.

(1) Anh em ta về cùng nhau ta quay quần (nhé)
một hai ba bốn năm. (2) Anh em ta về cùng
nhau ta xum họp (nhé) năm bốn ba hai một.
(3) Một đều chân bước nhé. (4) Hai quay nhìn nhau đi.
(5) Ba cầm tay chắc nhé không muốn ai chia lìa.
(6) Bốn nhớ rằng chúng ta bốn bề anh em một nhà.
(7) Năm nhớ mãi tình này trong câu ca.

Meaning of Song

It means we are all brothers and sisters gathered together to unite as one. We walk together, we acknowledge each other, we remain connected, and we retain the love for one another in our hearts through song.

NOTES:

